

# Luminous Infra-red Gas Heaters

## Version D-RAD

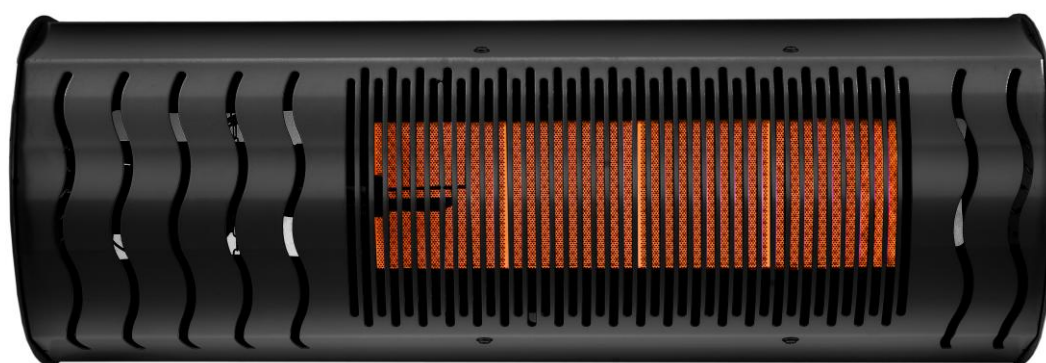

## ***MANUAL FOR INSTALLATION, RUNNING AND MAINTENANCE***



Models: 4P, 4PB  
6P, 6PB

**SIABS S.r.l.**

Viale del Lavoro 7  
20010 Casorezzo (Milan) -  
Italy

Phone +39 02 90384081

Email: [commerciale@siabs.it](mailto:commerciale@siabs.it)  
Web: [www.siabs.com](http://www.siabs.com)

## CONTENT

GENERAL INSTRUCTIONS for INSTALLER,.....	4
FOR YOUR SAFETY.....	5
Warranty.....	5
Plate label.....	6
Plate with technical data.....	6
Packing label.....	6
TECHNICAL DATA.....	7
INSTALLATION.....	8
Ventilation of the ambient.....	8
Positioning.....	9
Handling.....	10
MINIMUM height of installation (for people comfort).....	10
MINIMUM distances from flammable surfaces.....	11
Connection to GAS supply.....	11
Connection to ELECTRIC feeding.....	12
WIRING DIAGRAM, “SIT” control unit ON-OFF.....	14
NOTE for “SIT” TWO-STAGE gas valve.....	15
WIRING DIAGRAM, “SIT” control unit TWO-STAGE.....	17
FIXING BRACKETS.....	18
PUT IN OPERATION and FIRST START-UP.....	19
appliances with ELECTRONIC start-up.....	19
MAINTENANCE.....	20
Ordinary maintenance.....	20
Nozzle replacement.....	20
Trouble shooting.....	22
appliances with ELECTRONIC start-up.....	22
Serial number (bars code).....	23
Decommissioning and disposal.....	23
CE certificate.....	24
SERVICE SHEET.....	26



## **GENERAL INSTRUCTIONS for INSTALLER, USER and MAINTENANCE PERSONNEL**

**Thank you for your preference and trust granted!** SIABS is pleased to have You among his Customers; our appliances are designed and manufactured to the most modern and rational processing systems and we do think that their use will be fully satisfactory.

To keep appliances perfectly working and safe, time passing, we invite you to **read and follow the instructions** of this handbook and **commit all installation and maintenance (ordinary and extraordinary) operations only to skilled personnel**, with specific technical skills in the field of components of heating, preferably to SIABS authorized Service Centre.

### ***For the INSTALLER:***

- **read carefully the warnings** in the manual **before performing any operation** as they provide important information concerning the safety of installation, use and the necessary maintenance operations to be performed
- this manual is integral and essential part of the product and **must be delivered to the user; retain it carefully for further consultations**
- **in case of non-compliance with the following instructions, the warranty covering the product(s) will be null and void**
- **BEFORE THE INSTALLATION**, verify that local gas distribution (type of gas and pressure) and appliance settings are compatible
- appliance must be **installed only in premises with adequate ventilation**
- installation should be done in **accordance with the Regulations in force** in the country of destination, to the state of art, following instructions by the Manufacturer
- **incorrect installation can cause damage** to people, animals and things; the Manufacturer doesn't accept any contractual and extra-contractual liability in tort and contract for damages caused by errors in installation and use
- use only original accessories and modification kits
- after you have removed all items from packing box, **make sure that all components have been included and their integrity**, in case of doubt not use the appliance and contact the Manufacturer; elements of packaging are potentially dangerous: therefore, should not be left within the reach of children and must be disposed according to regulations in force
- before any cleaning or maintenance operation, **wait until the appliance is cold, disconnect it from the electricity supply and bring the fuel shut-off valve in the closed position**

### ***For the USER and OWNER of the plant:***

- this manual is integral and essential part of the product and **must be delivered to the user; retain it carefully for further consultations**
- **in case of non-compliance with the following instructions, the warranty covering the product(s) will be null and void**
- use only original accessories and modification kits
- in case of failure and/or malfunction of the appliance, turn it off refraining from any attempt to repair or direct intervention; **contact SIABS authorized Service Centre**
- when you decide to stop using the appliance, for **DISPOSAL or RESALE**, you will have to render harmless all parties which can be a source of potential danger; **the technical manual is integral and essential part of the product: it must be preserved and accompany the appliance in case of property change, so that it can be consulted by the new user and / or maintenance staff**

## FOR YOUR SAFETY



**In case of gas smell:** DO NOT operate the heating plant, vent the ambient, DO NOT start apparatus or electric switches; contact the installer and gas supply company and follow scrupulously their instruction

**IMPORTANT:** appliances **MUST NOT be used in domestic environments.** This appliance will be devoted only to the use for which it was expressly provided, **all other uses will be considered improper and therefore dangerous.**

**IMPORTANT:** appliances **MUST NOT be used in ambient with flammable materials, liquids or vapours:** non-compliance with these requirements may be cause of death, injury to persons or damage to things.

## Warranty

SIABS guarantees its products, whether installed by authorized personnel, for a period of 24 months from the invoice date. The warranty does not cover the components supplied by third parties, these are subject to the conditions of the original warranty.

The guarantee is only the free supply on Ex-Works basis, of parts with manufacturing or workmanship defects.

The guarantee does not cover problems due to carelessness, incorrect setting, misuse of the appliance or fortuitous accidents, and not dependent on imperfection processing or defective materials, and those due to dismantling or changes without prior authorization from SIABS.

The correct functioning of the appliances depends on a proper installation and start-up. Failure to comply with these rules immediately involves the decay of the guarantee, and therefore of responsibility by the manufacturer.

## Plate label

On each unit you will find a plate with technical data: **do not remove!**

### Plate with technical data

#### Apparatus type A1, gas category II 2H3B/P



This appliance must be installed in accordance with the rules in force. It shall be used in a space ventilated in accordance with the requirements of EN 13410. Consult the instruction before installation and use of this appliance.

Model **6 P** Code PIN **0476CT2372**   
 Version **D RAD** Country of destination **NL**  
 Gas category **II 2H3P A1** **0476/ 20**



 **Before making any operation, turn off GAS and disconnect the POWER**

Tension	230 volt	Gas type	G20
Frequency	50 Hz	Nominal heat input Hs MAX/MIN	9.6 kW
Absorbed power	24 Watt	Nominal heat input Hi MAX/MIN	8.6 kW
Protection rate	IP20	Gas consumption MAX / MIN	0.91 Kg/h
Nozzle diameter	2.45 mm	MAX feeding pressure	50.0 mbar
NOx category	4	Supply pressure	20.0 mbar
		Nozzle pressure MAX / MIN	14.0 mbar

**DO NOT USE IN DOMESTIC AMBIENT**

**Plate label** (example: appliance 4PB, version D-RAD, two-stages, G20 natural gas)

### Packing label

www.siabs.com Tel. +39 02 90384081

DESTINATION COUNTRY: SWEDEN  
 CATEGORIA GAS: II 2H3+ A1

Gas: G20/G20

Heaters: 6P

Version: D-RAD BLACK

Note: ON-OFF

 This appliance must be installed complying to the regulations in force. It must be installed only areas with the correct air changes, in compliance with the EN 13410 standard. Read the instructions before installing or using this appliance.

Essential features of the appliance are given on the packing label, outside on the packing box.

# TECHNICAL DATA

Model	Version	4PB	6PB	4P	6P
		TWO-STAGES			
Ceramic plates	nr.	4	6	4	6
Electric feeding		230 Volt - 50 Hz - 1 phase			
MAX pressure feeding	(mbar)	50,0		50,0	
Gas group	nr.	1	1	1	1
Gas connection		1 x 1/2"	1 x 1/2"	1 x 1/2"	1 x 1/2"
Absorbed power	(Watt)	24	24	24	24
NOx class		4	4	4	4
Weight	(kg)	11	14	11	14
Length (overall)	(mm)	700	895	700	895
Width	(mm)	295	295	295	295
Height	(mm)	231,2	231,2	231,2	231,2
<b>GAS G20</b>					
Heat input MAX (Hs)	(kW)	7,2	9,6	7,2	9,6
Heat input MAX (Hi)	(kW)	6,5	8,6	6,5	8,6
Heat input MIN (Hs)	(kW)	5,4	7,2	-	-
Heat input MIN (Hi)	(kW)	4,9	6,5	-	-
GAS supply pressure	(mbar)	20,0	20,0	20,0	20,0
NOZZLE pressure MAX	(mbar)	15,5	14,0	15,5	14,0
NOZZLE pressure MIN	(mbar)	8,5	7,5	-	-
Gas consumption MAX	(m <sup>3</sup> /h)	0,69	0,91	0,69	0,91
Gas consumption MIN	(m <sup>3</sup> /h)	0,52	0,69	-	-
Nozzle diameter	(mm)	2,10	2,45	2,10	2,45
<b>GAS G25</b>					
Heat input MAX (Hs)	(kW)	7,2	9,6	7,2	9,6
Heat input MAX (Hi)	(kW)	6,5	8,6	6,5	8,6
Heat input MIN (Hs)	(kW)	5,4	7,2	-	-
Heat input MIN (Hi)	(kW)	4,9	6,5	-	-
GAS supply pressure	(mbar)	25,0	25,0	25,0	25,0
NOZZLE pressure MAX	(mbar)	13,7	14,0	13,7	14,0
NOZZLE pressure MIN	(mbar)	8,3	7,5	-	-
Gas consumption MAX	(m <sup>3</sup> /h)	0,80	1,06	0,80	1,06
Gas consumption MIN	(m <sup>3</sup> /h)	0,60	0,80	-	-
Nozzle diameter	(mm)	2,30	2,70	2,30	2,70
Diameter diaphragm, gas G20 and G25	(mm)	2,90	3,30	2,90	3,30
<b>GAS G30</b>					
Heat input MAX (Hs)	(kW)	7,0	9,3	7,0	9,3
Heat input MAX (Hi)	(kW)	6,5	8,6	6,5	8,6
Heat input MIN (Hs)	(kW)	5,3	7,0	-	-
Heat input MIN (Hi)	(kW)	4,9	6,5	-	-
GAS supply pressure	(mbar)	30,0	30,0	30,0	30,0
NOZZLE pressure MAX	(mbar)	28,2	28,0	28,2	28,0
NOZZLE pressure MIN	(mbar)	16,5	16,0	-	-
Gas consumption MAX	(kg/h)	0,51	0,68	0,51	0,68
Gas consumption MIN	(kg/h)	0,39	0,51	-	-
Nozzle diameter	(mm)	1,30	1,50	1,30	1,50
<b>GAS G31</b>					
Heat input MAX (Hs)	(kW)	7,0	9,3	7,0	9,3
Heat input MAX (Hi)	(kW)	6,5	8,6	6,5	8,6
Heat input MIN (Hs)	(kW)	5,3	7,0	-	-
Heat input MIN (Hi)	(kW)	4,9	6,5	-	-
GAS supply pressure	(mbar)	37,0	37,0	37,0	37,0
NOZZLE pressure MAX	(mbar)	36,2	35,7	-	-
NOZZLE pressure MIN	(mbar)	22,0	20,0	22,0	20,0
Gas consumption MAX	(kg/h)	0,50	0,67	0,50	0,67
Gas consumption MIN	(kg/h)	0,38	0,50	-	-
Nozzle diameter	(mm)	1,30	1,50	1,30	1,50

# INSTALLATION

## Ventilation of the ambient



**Appliances must be installed in well-ventilated and manned ambient, in compliance with current legislation**

The unit leaves the combustion products into the environment in which it is used (appliance type A1). It is therefore necessary to **ensure ventilation and air changes of the premises in which the appliance is installed**, realizing appropriate air outlet openings on the perimeter walls of the same, or creating a system of mechanical ventilation. To ensure a sufficient air change, the flow of air needed can be calculated using the following equation (UNI EN 13410):

$$V_{\text{tot}} = \Sigma Q_{\text{nb}} \times L$$

- $V_{\text{tot}}$  air change flow rate in  $\text{m}^3/\text{h}$
- $\Sigma Q_{\text{nb}}$  total heating power installed in the premises in kW
- $L$  air change coefficient (must be  $\geq 10 \text{ m}^3/\text{h} / \text{kW}$ )

**IMPORTANT:** air change coefficient "L" to be used **MUST NOT** be lower than **10  $\text{m}^3/\text{h}$  for each kW of installed power**

**For NO reason the appliance(s) can be installed:**

- in rooms smaller than **12  $\text{m}^3$**
- in ambient used as residential ambient
- where wind speed is higher than **2 m/s**

## Positioning

The appliances can be installed on walls, or hanging at ceiling with chains. On request, we can provide **brackets** to fix the **heaters on the wall** (picture 1) with different angled positions, **or for suspension at ceiling** (picture 2); S hooks and chains are excluded.



picture 1 – Installation at wall **D-RAD**



picture 2 – Installation with chains **D-RAD**

The brackets provided by SIABS allow an angle of installation variable once mounted on a wall or pillar, in order to get a better heat distribution (picture 3, supports for DCeco version)



picture 3 – different angles: 5°, 15°, 30°, 45°

### IMPORTANT!

- at each side of the burner 2 hooks are provided with M8 inserts, for fixing to a wall or at ceiling by means of appropriate brackets (not supplied, available on request); **do not create other anchor points on the carpentry of the heater and in particular on the body burner, but use only those designed by the factory**
- **we recommend SIABS original brackets** for installation of the radiant heaters
- for fixing brackets on a wall or pillars **assess the consistency of walls and the load applied, in order to choose the correct anchors to be used**; in any case provide blocks with M8 screw minimum diameter (e.g. anchor Fischer TA - M in steel, with M8 screw)

**IMPORTANT:** appliances must be installed **in horizontal position**, contact us in case of different inclination. In any case, the system of fixing / suspension must allow thermal expansion of appliance (some millimetres depending on the model).

## Handling

During extraction of the appliances from package and for all operations of handling till final place of installation, gas valves / flame controls of injection group must **NOT** be used as lifting points.

Appliances must be taken at the installation point / height inside its package or using M8 inserts: **all other parts of the appliances are NOT designed to withstand its weight.**

*NB – The unit is delivered with a protective film; **we recommend you remove it after finishing the installation, at the end of the works.***

### MINIMUM height of installation (for people comfort)

Indicative heights for the installation of appliances are as follows:

MODEL	HEIGHT of INSTALLATION (mt)
4P	2,5
6P	3,0

Height "MIN" means the minimum height at which the appliance should be installed so that people who are in radiated zone, **are not subject to excessive heat.**

Quotes relate to appliances **installed in horizontal position**; for appliances with angled position (15 ÷ 60 °), the minimum height can be reduced roughly between a 5 % (15 ° angle) and a 20 % (60 ° angle).

Quotes relate to installation with **ambient temperature of 10 ÷ 12 °C**; in case of ambient with higher or lower temperatures the minimum height of installation must be reviewed; consider a reduction of 5 % (for temperatures lower of approx. 5 ° C) or increase of 5 % (for temperatures higher of approx. 5 ° C).

Above MINIMUM **heights of installation are indicative**, consult us each case to select the most advisable unit and the best height of installation (mostly for limit values), and for doubts about MAXIMUM height of installation.

## MINIMUM distances from flammable surfaces

**IMPORTANT:** flammable materials inside the radiation could begin to burn and cause fires.



**SURFACES CLOSE to APPLIANCES MUST BE DONE IN MATERIAL of CLASS 'A0' with respect TO FIRE RESPONSE (NOT COMBUSTIBLE and NOT FLAMMABLE) and with DEGREE of RESISTANCE TO FIRE EQUAL or MORE THAN "REI 90"**

Minimum distances of installation must be respected between the heating surface of the appliances and the adjacent walls, **inside the area of radiation and outside**, if they are not protected against radiation or are flammable materials; in case below minimum distances cannot be met, consider to mount screens for the heat.

Pay special attention also in cases of installing appliances above crane ways, to prevent damage to motor and electric cables!

The **MINIMUM** distances are as follows:

MODEL	MINIMUM distance (mt) between heater and ...			
	ceiling	floor	front	sides
4P	1,0	2,0	1,0	1,0
6P	1,0	2,5	1,0	1,0

**NOTE – contact us in case of different distances or special cases**

## Connection to GAS supply

**IMPORTANT:** hydraulic connection of the appliances to the gas distribution net must be made according to information given in this technical book exclusively by professionally qualified staff.

The appliances are supplied according to the type of gas chosen, and then before making the connection to the power network of gas, **make sure that the gas used and pressure of gas circuit correspond to what is shown on the data plate label** of the unit. **Before connection to the gas pipeline, make sure that the pipes are properly cleaned and produced in accordance with regulations in force in the country of installation.**

**NOTICE:** provide a **fuel interception tap** close to the appliance, and with easily accessible position; make the **connection between the appliance and the gas network using an approved steel flexible pipe.**

**IMPORTANT: "GAS supply pressure", defined as the dynamic pressure of the circuit, or part of the circuit downstream of the pressure reducer, with all the appliances running, and must be detected in this condition. With lower pressure difficulties in start-up may occur.**

Once the connection is made, **in compliance with the rules in force in the country of installation, a)** verify the sealing of hydraulic pipes and gas connection to the unit, **b)** check that the pressure is correct, **c)** make sure that the apparatus functions in the conditions for which it was prepared.

**ELECTRONIC start-up APPLIANCES:** gas connection is 1/2"; appliances are equipped with a multifunctional group comprising: double seat valve fitted with pressure stabilizer and integrated flame control. **The stabilizer accepts a maximum inlet pressure of 50 mbar** and the valve is equipped with a pressure intake, to measure and control incoming and outgoing pressures.

**IMPORTANT:** all appliances are **supplied already tested and set** to the properly operating pressure; **DO NOT remove seal on the pressure regulator (R): expiring of guarantee!**



Feeding gas pipeline **must be kept at a distance of at least 1 m from the zone of discharge of the combustion products** and **must not be exposed to direct irradiation of appliances**

## Connection to ELECTRIC feeding

**IMPORTANT:** the **electrical connection of the equipment shall be made in accordance with the directions given in this technical book** exclusively by professionally qualified personnel. **The installation must be carried out in accordance with regulations in the country of installation.**

The appliance must be fed with 230 Volt / Single Phase / 50 Hz feeding. The control flame mounted on gas valve has a plug/socket connection with security hook (picture 3). Mount a bipolar switch upstream of the heater for switch-on and switch-off, so you can isolate it from electric supply. Use this manual for the size of the power supply line, or refer to the data given in the plate label of the heater. In any case, use a cable with minimum section 3x1.5mm<sup>2</sup> (ON-OFF version) or 4x1.5mm<sup>2</sup> (TWO-STAGE version).

The wiring diagrams are shown on page 13 (ON-OFF version) and page 16 (TWO-STAGE version) of this manual.

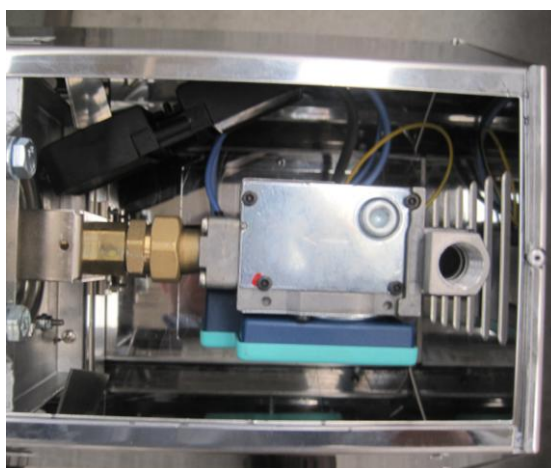

Picture 3 – Connector for electric connection

For the electrical connection unlock the plug and unscrew its case; connect a cable according to the indications given on the terminal plug, namely:

- L1** phase wire
- N** neutral wire
-  earth wire
- L2** modulator command for two-stages gas valve (if provided)
- L3** signal for burner block (if provided)

**IMPORTANT:** it is **essential** for the smooth functioning of the appliances, to **respect the Phase / Neutral polarity**, with that indicated on the power connector.

**IMPORTANT:** for safety of the user, and smooth functioning of the appliances, heater must be equipped with **efficient plant grounding**, executed according to existing regulations in the Country of installation. Under no circumstances you can use the gas connection pipeline as grounding of equipment.

## WIRING DIAGRAM, "SIT" control unit ON-OFF

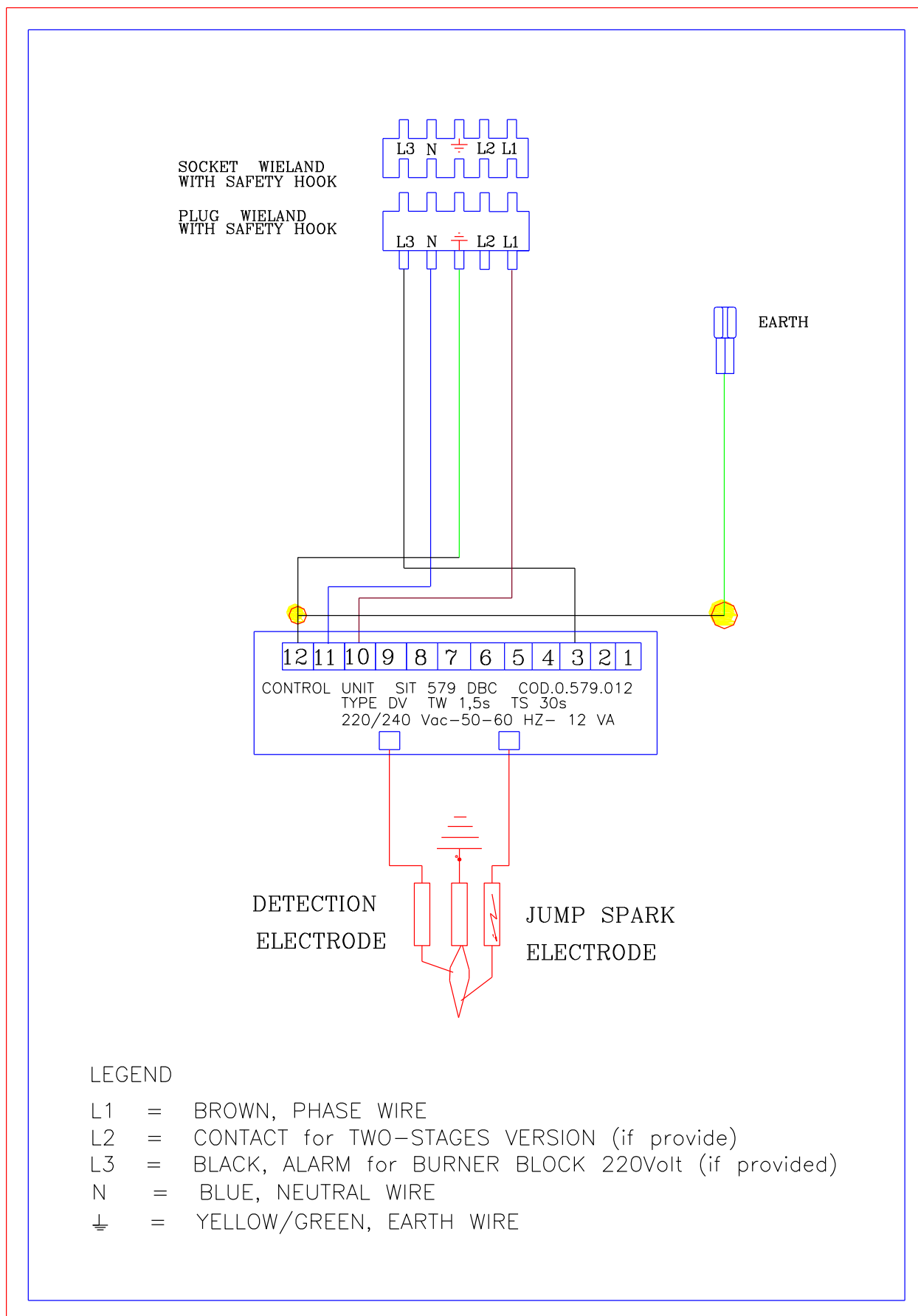

## NOTE for "SIT" TWO-STAGE gas valve

### IMPORTANT:

- for this version, a specific switch for pressure modulator feeding must be placed in the main electric switchboard
  - modulator fed: HIGH pressure running
  - modulator NOT fed: LOW pressure running
- start-up of the appliance **must always take place** with the modulator fed (HIGH pressure running)
- you will find the data (heat input, pressure and gas flow rate) referring to the appliances with TWO-STAGE version, in the tables at page 6 of this manual.

**N.B. – MINIMUM heating capacity = feed L1 + N**  
**– MAXIMUM heating capacity = feed L1 + L2 + N**

You will find the data (heat input, pressure and gas flow rate) referring to the appliances with TWO-STAGE version, in the tables at page 6 of this manual.

The TWO-STAGE version allows:

- save on gas consumption
- better comfort condition for people
- lower number of start-up / switch-off of the heater
- power reserve for particularly cold winters

## Setting of the pressure

Unscrew the screw of the **PO** pressure intake of the gas valve before the nozzle (pictures 1.A and 1.B), and connect a water column manometer. Feed the modulator and take out the yellow tap of the pressure regulator. Act, as shown in picture 2, on the CH10 screw for setting of the maximum pressure, till you get the required pressure (**turn clockwise to increase and counter clockwise to decrease**). Take out tension at the pressure modulator, and with a screw-driver act on the inner screw for minimum setting (picture 3) till you get the required pressure (**turn clockwise to increase and counter clockwise to decrease**).

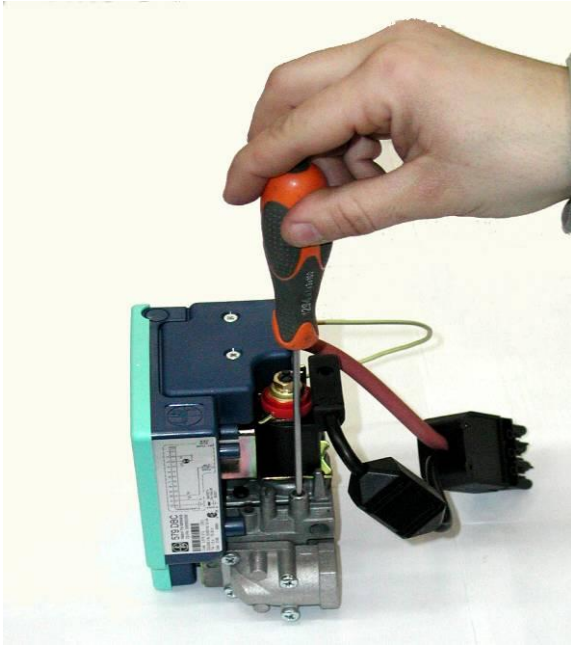

Picture 1.A

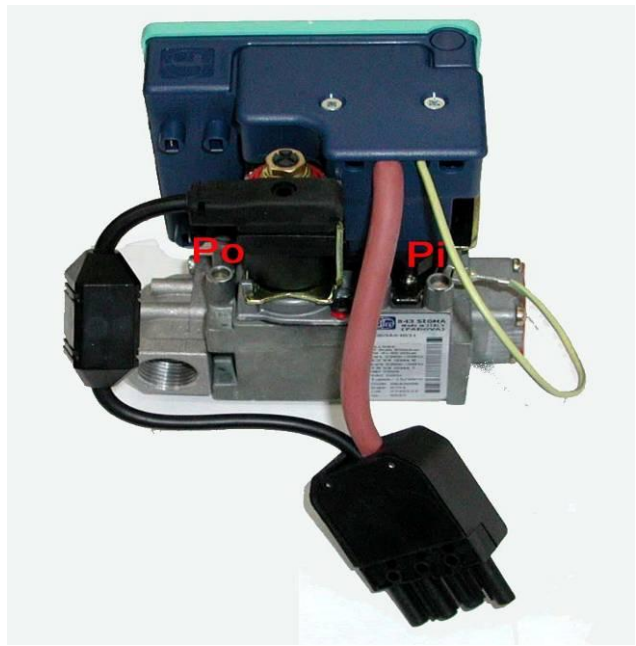

Picture 1.B



Picture 2





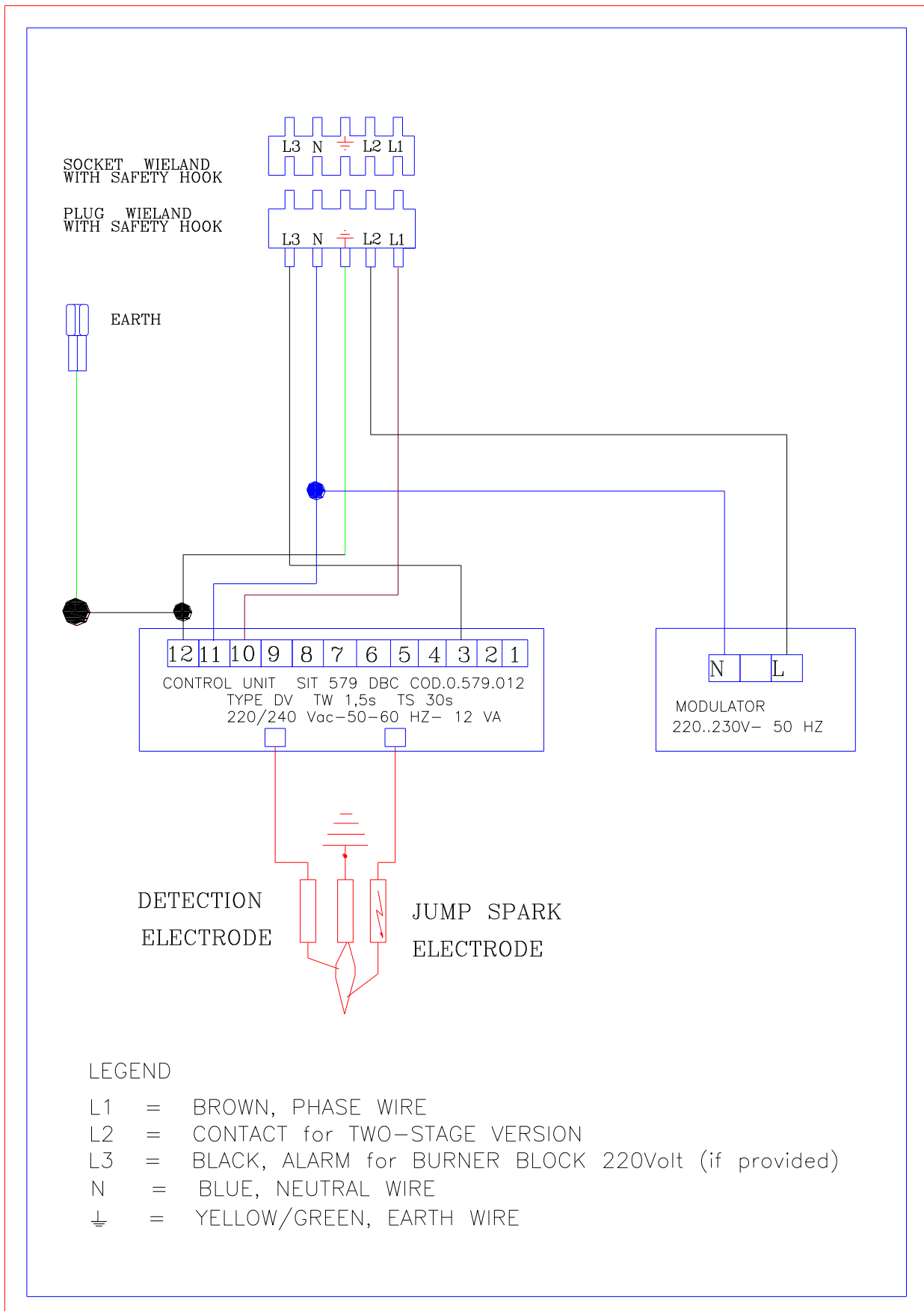

Picture 3

**WIRING DIAGRAM, "SIT" control unit TWO-STAGE**

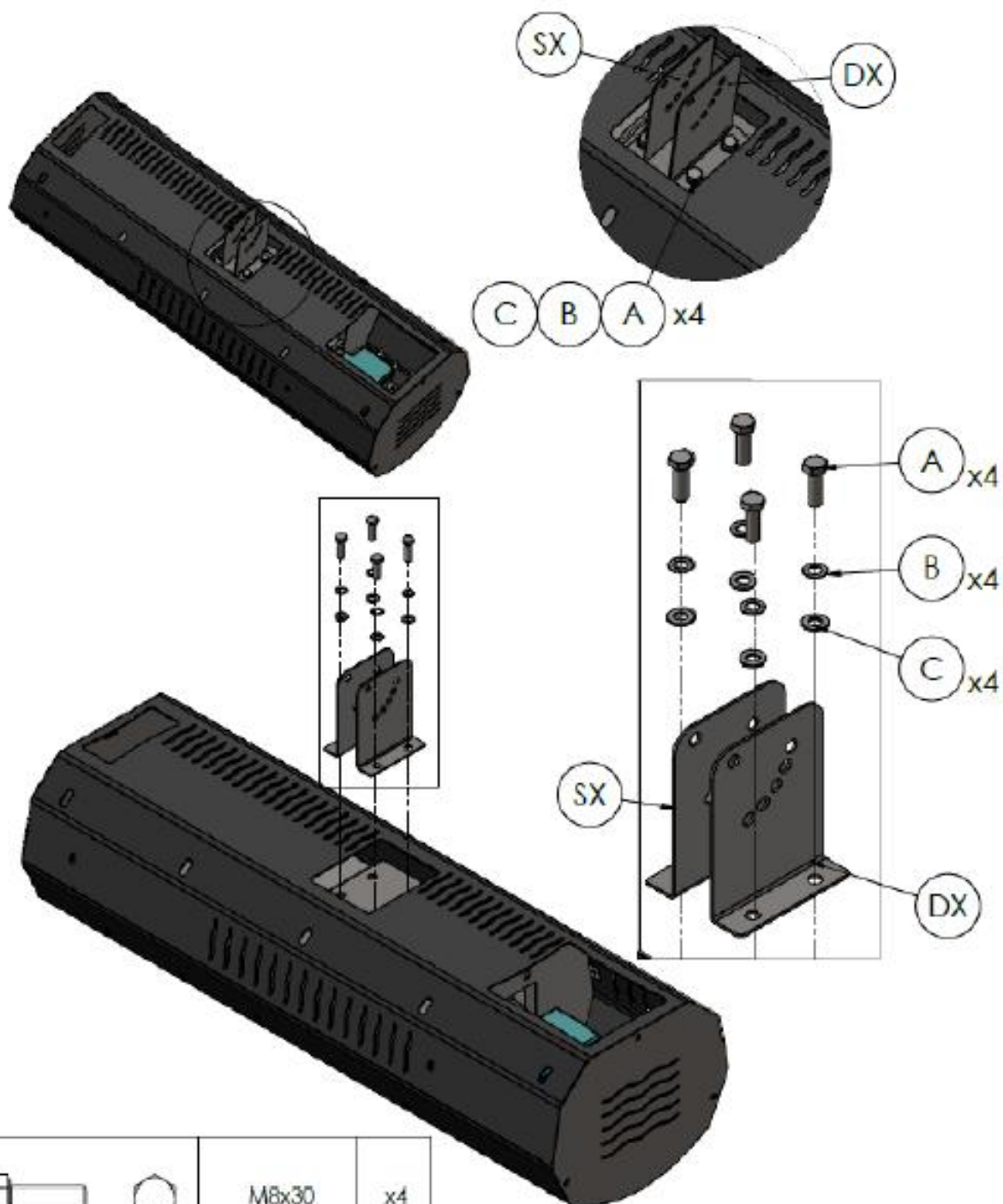

## FIXING BRACKETS



A		M8x30	x4
B		Ø8	x4
C		Ø8	x4

## PUT IN OPERATION and FIRST START-UP

When you first start the appliances is important to **make some preliminary checks** to ensure its proper running; operations listed below are considered essential:

- make sure there are no losses in the gas line and that is properly sized
- **check that the pressure and type of gas used comply with the data on the plate of the characteristics of the appliance**
- check that the power electric line has been correctly sized, which has been respected phase - neutral polarity and that the cable grounding is connected
- make sure the mechanical installation (supports) of the appliance have been properly carried out and that the connections bolts are tight
- use only steel materials, since heat is transferred from appliances to supports

## PUT IN OPERATION and FIRST START-UP, appliances with ELECTRONIC start-up

Start-up sequence includes the following phases:

- giving tension to the appliances, ignition electrode begins sparking, and the gas valve opens
- the sparking electrode ends after 30 seconds
- in the case has not been detected the presence of flame, control flame goes into block after 30 seconds; for re-start it is necessary to remove tension for a period of not less than 20 seconds: after that period of time, the start-up sequence can be repeated; if the heater continues going into block, refer to the section 'Maintenance' of this manual
- switch-off of the heater is done by taking out power supply to control unit

**IMPORTANT:** in case of failure at time of first start-up, **pressure settings have to be checked, acting on PO and PI pressure intakes**

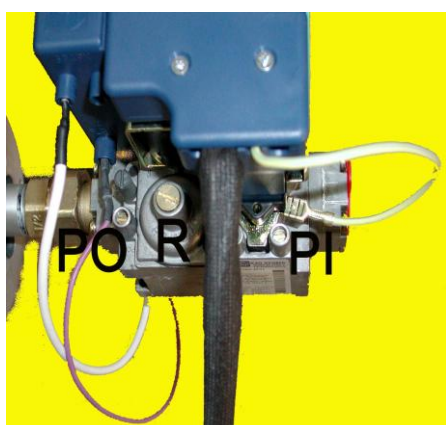

**Only in case of maintenance**, following instruction of qualified SIABS personnel, pressure settings can be modified using the following procedure:

- remove the cap of pressure regulator (R)
- unscrew the screw of intake pressure, upstream at the nozzle (PO) and connect a suitable gauge, to check correct pressure during setting
- remove the cap of pressure regulator (R) and act, as shown in pictures (**turn clockwise to increase and counter clockwise to decrease**), on the screw of

adjustment till match up to the pressure gauge reading with that stated on plate on the characteristics

- the new and correct nozzle pressure should be checked at intake pressure PO
- disconnect the pressure gauge and close the screw of intake pressure (PO)
  - reassemble the cap of the regulator R and place a new suitable seal

## MAINTENANCE

### Ordinary maintenance

An appropriate use of the appliances, plus their proper and regular maintenance are essential to ensure better performance and longer working life.



**Before making any maintenance, make sure that both the gas and the power supply have been excluded, and that the apparatus is cold.** For all routine and / or extraordinary maintenance, contact only professionally qualified staff, or rather a Technical Assistance Centre authorized by SIABS

**At least once a year before the season of use**, it is strongly advisable to perform an intervention for control / inspection and cleaning:

- visual inspection of radiant surface (if any cracked ceramic plate)
- cleaning of radiant surface with compressed air with NO HUMIDITY at LOW PRESSURE from inside
- nozzle cleaning
- electrodes cleaning, correct position and efficiency sparking
- check of keeping all the electrical connections
- search for possible losses on the gas circuit and gas valve
- check of gas pressure at nozzle
- general control of all components of the appliance
- control of openings and ventilation systems (natural and/or mechanical)
- control of alarm signals, if any

If the appliances are installed in dusty environments is advisable to clean more frequently the burners blowing compressed air at low pressure, working from holes in the flange / venturi pipe. In case the appliance is running, shut it down and wait, before you blow, that it is cold.

### Nozzle replacement

In case you need to change the type of gas for which the appliance was prepared, you should contact SIABS to get the specific transformation kit, specifying the model of appliance, serial number and the new gas. The operations must be performed by qualified personnel and in compliance with the regulations.

Act as follows:

- unscrew and take out the gas nozzle using a CH13 spanner
- screw properly new gas nozzle

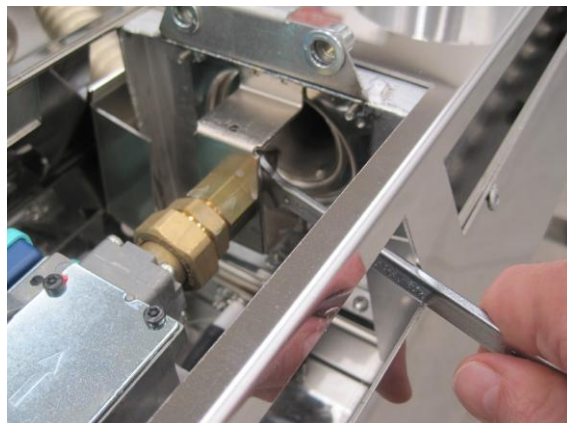
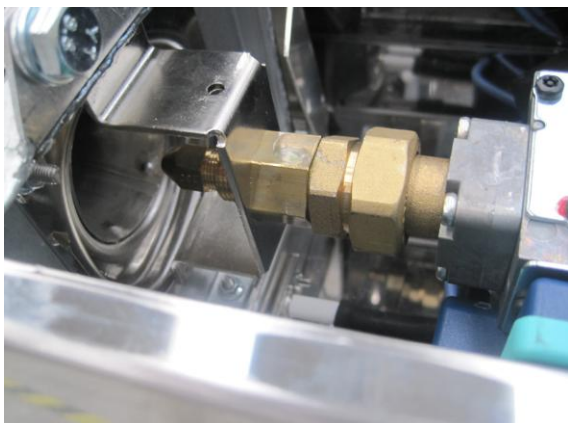
**N.B. – appliances running with G31 / G30 gases**

- some models require a special plate to be mounted on flange (reduction of air intake)
- dismantle the plate (if mounted) in case of change from G31 / G30 gas to G20 gas
- mount the plate (if supplied) in case of change from G20 gas to G31 / G30 gas

## Trouble shooting appliances with ELECTRONIC start-up

TROUBLE	POSSIBLE CAUSE	SOLUTION
<b>A</b> the heater turns on, the ignition electrode continues to sparkle then goes to block	<b>A1</b> Phase and Neutral with wrong connection <b>A2</b> The flame detection electrode is too far from the plates superface <b>A3</b> The control unit is defective	<b>A1</b> Check Phase / Neutral polarity and eart connection <b>A2</b> Verify that the flame detection electrode is approx. 4 mm from the radiant surface <b>A3</b> Replace the control unit
<b>B</b> the heater turns on partially	<b>B1</b> Insufficient gas flow <b>B2</b> Inlet gas pressure of the burner is too low <b>B3</b> Dirty nozzle	<b>B1</b> Check that gas supply has sufficient flow rate compared to gas consumption of the heater <b>B2</b> Check that the gas pressure corresponds to that shown on the plate label <b>B3</b> Clean nozzle with compressed air (NO mechanical device)
<b>C</b> the burner does flash-back	<b>C1</b> Inlet gas pressure of the burner is too high <b>C2</b> Burner or ceramic plates are dirty <b>C3</b> Ceramic plates are cracked	<b>C1</b> Check that the gas pressure corresponds to that shown on the plate label <b>C2</b> After burner is cold, blow air at low pressure on the ceramic plates surface, from inside <b>C3</b> Replace the ceramic plates
<b>D</b> the heater doesn't turn because no gas is getting	<b>D1</b> Interruption in the elctric plant <b>D2</b> No tension <b>D3</b> Solenoid valve is live, but coils are not energized	<b>D1</b> Verify voltage at connector of power supply <b>D2</b> Replace the control unit <b>D3</b> Replace the gas valve
<b>E</b> the ignition electrode doesn't sparkle, and burner goes to block	<b>E1</b> The electrode doesn't spark because of wrong distance between its tip and earth <b>E2</b> Power interruption <b>E3</b> The spark of the ignition electrode starts close to the ceramic protection, due to its breakcage, or between cable and mass	<b>E1</b> Adjust distance (closer or further) between tip of ignition electrode and mass : should be 3 ÷ 4 mm <b>E2</b> Check contacts connection of electrodes and control unit <b>E3</b> Replace the whole ignition and detection devi or just the cable, or just the electrode
<b>F</b> the gas valve turns on, but the heater doesn't turn and goes to block	<b>F1</b> Air in the gas pipe <b>F2</b> No gas	<b>F1</b> Repeat the ignition cycle several times, waiting a time of approx. 20 sec between an ignition and the other <b>F2</b> Verify that all devices of fuel interception, on gas pipeline, do not prevent passage

## Serial number (bars code)

It is advisable to communicate us the **serial number** of the appliance(s) (label with bars code) for all operation of regular or extraordinary maintenance, and for orders of spare-parts.



On the appliance



Outside, on packing box

## Decommissioning and disposal

**INFORMATION TO USERS** "Implementation of Directives 2002/95/EC, 2002/96/EC and 2003/108/EC, relating to the use of hazardous substances in electrical and electronic equipment, as well as waste disposal"

The product at the end of its useful life **must be separated from other waste**. You should therefore **give the equipment at end of its working life to appropriate separate collection centres of electric and electronic waste**, or return it to the dealer when purchasing a new device to be equivalent in terms of one to one.

The proper differentiated collection to deliver the decommissioned apparatus to recycling, treatment and environmentally compatible disposal, helps to avoid possible negative effects on environmental and health, and promote the recycling of materials making up the equipment.

Illegal disposal of the product by the holder imply the application of administrative penalties according to law.



**N.B. – Do not dispose of the product in mixed waste**

# CE certificate



CERTIFICATE

<b>Number</b>	KIP-07973	<b>Replaces</b>	KIP-15966/G Rev.1
<b>Issue date</b>	22-07-2025	<b>Contract number</b>	I 9100
<b>Due date</b>	21-07-2035	<b>Scope</b>	(EU) 2016/426 (9 March 2016)
<b>Report number</b>	2002372/2	<b>Module</b>	B (Type testing)
<b>PIN</b>	0476CT2372		

## EU TYPE-EXAMINATION CERTIFICATE (GAR)

Kiwa Cermet Italia declares that the Gas-fired overhead luminous radiant heaters for non-domestic use, types(s):

**4P, 4PM, M4D/08, UFO EB/08, 4PB, 6P, 6PM, M6D/08, ST6/08, 6PB, 8P, ST8/08, 8PB, 10P, 10PB, 10+10P, 10+10PB, 12PR, 12PRB, 12P, 12PB, 12+12P, 12+12PB, 16P, 16PB, 16+16P, 16+16PB**

Manufacturer

**SIABS S.r.l.**  
**Via Giuseppe Parini, 1**  
**23845 Costa Masnaga (LC) - Italy**

Meet the essential requirements as described in the  
**Regulation (EU) 2016/426 relating to appliances burning gaseous fuels.**

Reference standard: EN 419:2019

This certificate is only valid in combination with the appendix to this certificate, where specific information and/or conditions are given.

**Industry Division Manager**  
Maurizio Lorenzon

Kiwa Cermet Italia S.p.A.  
 Società con socio unico, soggetta  
 all'attività di direzione e coordinamento  
 di Kiwa Italia Holding Srl  
 Via Cadriano, 23  
 40057 Granarolo dell'Emilia (BO)

**Unità locale**  
 Via Treviso 32/34  
 31020 San Vendemiano (TV)  
 Tel +39. 0438 411755  
 Fax +39.0438 22428  
 E-mail: [info@kiwacermet.it](mailto:info@kiwacermet.it)  
[www.kiwa.it](http://www.kiwa.it)

**Organismo Notificato n. 0476**  
 Notified Body nr. 0476



PRD N° 0069PRD  
 Membro degli Accordi di Mutuo Riconoscimento EA, IAF e ILAC  
 Signatory of EA, IAF and ILAC Mutual Recognition Agreements



**Number** KIP-07973 **Page** 1 of 1  
**Issue date** 22-07-2025 **Scope** (EU) 2016/426 (9 March 2016)  
**Due date** 21-07-2035 **Module** IB (Type testing)  
**Report number** 2002372/2  
**PIN** 0476CT2372

## APPENDIX TO EU TYPE-EXAMINATION CERTIFICATE (GAR)

Brand name: **SIABS**

Types:

Models	Qnom (Hi) kW	Models	Qnom (Hi) kW	Models	Qnom (Hi) kW
UFO EB/08	7,5 – 10,0	6PB	6,5 – 8,6	12P	20,0
4P	6,5	8P	14,5	12PB	15,0 – 20,0
4PM	6,5	ST8/08	14,5	12+12PB	15,0 – 40,0
M4D/08	6,5	8PB	10,9 – 14,5	12+12P	40,0
4PB	4,9 – 6,5	10P	16,5	16P	31,0
6P	8,6	10PB	12,4 – 16,5	16PB	28,0 – 31,0
6PM	8,6	10+10P	33,0	16+16P	62,0
M6D/08	8,6	10+10PB	12,4 – 33,0	16+16PB	28,0 – 62,0
ST6/08	8,6	12PR	17,1	12PRB	12,8 – 17,1

Heat input values refer to G20 20mbar.

Appliance types:

A<sub>1</sub>

Countries:

AT, BE, BG, CH, CY, CZ, DE, DK, EE, ES, FI, FR, GR, HR, HU, IE, IT, LT, LU, LV, MT, NO, NL, PL, PT, RO, SE, SI, SK, TR

Gas groups:

Group	mbar	Group	mbar	Group	mbar
E	20	L	20	P	30; 37; 50
E+	20/25	LL	20	B	30; 50
H	20;25	3+	28-30/37	B/P	30; 50

The above gas groups can be combined according to the standard EN437:2021 and national situation of countries.

Remarks: –

The validity of this certificate can be verified on request at the following email address: [info@kiwacermet.it](mailto:info@kiwacermet.it)  
 This certificate will expire if there have been any changes to the product that may have an impact on compliance with the requirements of the Directive. This certificate will expire if there have been any updates and/or changes to the Technical Standards applicable unless specifically approved by Kiwa Cermet Italia.  
 Any total or partial reproduction of this document in any form, without Kiwa Cermet Italia express authorization, is prohibited.

**SERVICE SHEET**  
OPERATION / NOTES

DATE and STAMP

---

---

---

---

---

---

---

---

DATE and STAMP

OPERATION / NOTES

---

---

---

---

---

---

---

---

DATE and STAMP

OPERATION / NOTES

---

---

---

---

---

---

---

---

DATE and STAMP

OPERATION / NOTES

---

---

---

---

---

---

---

---

**SIABS S.r.l.**  
**via Del Lavoro, 7**  
**20003 – Casorezzo (MILAN)**  
**ITALY**

---

to contact us:

Phone       +39 02 90384081  
E-mail       [commerciale@siabs.it](mailto:commerciale@siabs.it)  
Web page    [www.siabs.it](http://www.siabs.it)

Continuous development to improve the product could cause changes of above without notice.